

## Stationary High Pressure Compressor for Air and Breathing Air Compression up to 420 bar

Types:

**MV260/420 | MV320/420 | V450/420 |  
V560/420**

Production status: F01



VERTICUS 420 bar in Super Silent version

General	
Medium	Air
Intake pressure	Atmospheric
Filling pressure	PN200 / PN300 / PN420
Pressure setting, final pressure SIV	225 bar / 330 bar / 350 bar / 420 bar
Pressure setting, pressure sensor	220 bar / 320 bar / 340 bar / 400 bar
Permissible ambient temperature range	+5...+45°C
Permissible altitude	0...1500 m AMSL
Max. permissible tilt	5°
System type	Open / Super Silent
Standard operating voltage	400 V; 50 Hz
Other operating voltage	On request
Compressor oil, standard	Synthetic
Oil change interval	Synthetic : every 2 years / 2,000 h
Finish	RAL 7024, RAL 9006, CYAN (front) / RAL 9006 (sides)

# (MINI-)VERTICUS 420 bar

Compressor system	MV260/420	MV320/420	V450/420	V560/420
Charging rate <sup>1</sup>	260 l/min	320 l/min	450 l/min	560 l/min
Purification system	P61/420	P61/420	P61/420	P61/420
Sound pressure level <sup>2</sup> (Super Silent version)	67 dB(A)	70 dB(A)	70 dB(A)	73 dB(A)
Weight (Super Silent) <sup>3</sup>	399 kg	406 kg	472 kg	472 kg
Weight (open model) <sup>3</sup>	349 kg	356 kg	408 kg	408 kg
Dimensions (LxWxH) Super Silent <sup>3</sup>	1352 x 790 x 1375 mm <sup>4</sup>		1537 x 790 x 1525 mm <sup>4</sup>	
Dimensions (LxWxH) open <sup>3</sup>	1195 x 790 x 1375 mm		1195 x 790 x 1525 mm	

1 Measured during cylinder filling from 0-200 bar tolerance +/- 5% at + 20°C ambient temperature.

2 According to ISO 3744.

3 Standard model. Weight and dimensions may vary depending on accessories.

4 Width without removable doors, width including doors: 802 mm.

The compressor frame, housing and load-bearing parts are metal (primer and painted finish); the front housing and control unit cover are of solid plastic (painted finish). Control box located on the left side of the compressor unit. Ergonomic access by folding out.

Drive system: e-motor	MV260/420	MV320/420	V450/420	V560/420
Motor	Three-phase			
Power	5.5 kW	7.5 kW	11 kW	15 kW
Operating voltage / frequency <sup>1</sup>	400 V, 50 Hz			
Speed	2,850 1/min	2,850 1/min	2,850 1/min	2,850 1/min
Protection class	IP55 (TEFC)			

1 Different voltage / different frequency available at extra charge on request.

STANDARD SCOPE OF SUPPLY:

➤ **Compressor block with following features**

- Oil pump for forced-feed lubrication
- Micronic intake filter: 10 µm
- Intermediate coolers, air cooled, stainless steel
- Aftercooler, air cooled, outlet temperature approx. 10-15 °C above cooling air temperature
- Intermediate separators after each stage (except 1st stage)
- Sealed safety valves after each stage
- TÜV approved final pressure safety valve
- Pressure maintaining and check valve after the final stage

Compressor block	IK12.14	IK15.11	IK18.1
Charging rate <sup>1</sup>	260 l/min 320 l/min	450 l/min	560 l/min
Speed	1,185 1/min 1,450 1/min	1,320 1/min	1,490 1/min
Number of stages	4	4	5
Number of cylinders	3	4	4
Cylinder bore 1st stage	105 mm	110 mm	120 mm
Cylinder bore 2nd stage	88 mm	60 mm	85/60 mm
Cylinder bore 3rd stage	28 mm	32 mm	32 mm
Cylinder bore 4th stage	12 mm	12 mm	18 mm
Cylinder bore 5th stage	-	-	10 mm
Stroke	40 mm	50 mm	50 mm
Direction of rotation (from flywheel side)	Left	Left	Left
Drive type	V-belt	V-belt	V-belt
Intermediate pressure 1st stage	3.4 – 4.2 bar	2.0 – 2.3 bar	2.9 – 4.5 bar
Intermediate pressure 2nd stage	14 - 18 bar	16 - 17 bar	13 - 15 bar
Intermediate pressure 3rd stage	53 - 82 bar	71 - 96 bar	42 - 48 bar
Intermediate pressure 4th stage	-	-	121 - 168 bar
Compressor block oil volume	2.8 l	6.0 l	6.0 l
Oil pressure	4.5 bar ± 1,5 bar	4.5 bar ± 1.5 bar	4.5 bar ± 1.5 bar
Intake pressure / Inlet pressure	1.0 bar <sub>a</sub>	1.0 bar <sub>a</sub>	1.0 bar <sub>a</sub>

<sup>1</sup> Measured during cylinder filling from 0-200 bar tolerance +/- 5% at + 20°C ambient temperature.

➤ **P41/420 Purification System - Filter with separate oil and water separator (for MINI-VERTICUS)**

**SCOPE OF DELIVERY:**

- 1x filter housing with long-life filter cartridge
- Separator unit with final pressure safety valve
- Check valve between separator and micro filter
- Micro filter
- Air bleeder valve with manometer
- Pressurizer / check valve
- Filter key for cartridge renewal



P41/350 purification system (picture similar)

**Air quality as per DIN/EN 12021:2014:**

Contamination	Maximum content as per DIN EN 12021:2014	Air quality by BAUER
H <sub>2</sub> O	25 mg/m <sup>3</sup>	≤ 10 mg/m <sup>3</sup>
CO	5 ppm(v)	Depending on filter cartridge <sup>1</sup>
CO <sub>2</sub>	500 ppm(v)	Depending on intake air <sup>2</sup>
Oil	0,5 mg/m <sup>3</sup>	≤ 0,1 mg/m <sup>3</sup>

1 Only with BAUER special filter cartridge with hopcalite up to a maximum concentration of 25 ppm CO in intake air. The compressed clean breathing air then contains a maximum of 5 ppm CO.

2 Where the intake air exceeds the maximum permissible level of CO<sub>2</sub> as per DIN EN 12021:2014, use of a BAUER AERO-GUARD system is **urgently recommended!**

Purification System	P41/420
Operating pressure (Standard)	PN200/PN300/PN420
Operating pressure max (safety valve setting)	420 bar
Pressure dew point	< -20 °C, equivalent to 3 mg/m <sup>3</sup> at 300 bar
Piping connections	G 3/8" (condensate drain G 1/4")
Filter housing volume	2.1 l
DGRL 2014/68/EU	Vessel category II
Air purification capacity (at ambient temperature 20°C and 300 bar) <sup>1</sup>	1,595 m <sup>3</sup>

1 When using a BAUER P41/420 filter cartridge without hopcalite. When using a cartridge with CO-removal, the air purification capacity is reduced by ca. 15 %. Different values for SECURUS cartridges.

➤ **P61/420 Purification System - Filter with separate oil and water separator (for VERTICUS)**

**SCOPE OF DELIVERY:**

- 1x filter housing with long-life filter cartridge
- Separator unit with final pressure safety valve
- Check valve between separator and micro filter
- Micro filter
- Air bleeder valve with manometer
- Pressurizer / check valve
- Filter key for cartridge renewal



P61 purification system (picture similar)

**Air quality as per DIN/EN 12021:2014 (see above)**

Purification system	P61/420
Operating pressure (Standard)	PN200/PN300/PN420
Operating pressure max (safety valve setting)	420 bar
Pressure dew point	< -20 °C, equivalent to 3 mg/m <sup>3</sup> at 300 bar
Piping connections	G 3/8" (condensate drain G 1/4")
Filter housing volume	2.85 l
DGRL 2014/68/EU	Vessel category II
Processable air capacity (with ref. 20°C and 300 bar) <sup>1</sup>	2,475 m <sup>3</sup>

<sup>1</sup> When using a BAUER P61 filter cartridge without hopcalite. When using a cartridge with CO-, the air purification capacity is reduced by approx. 10 %. Different values for SECURUS cartridges.

➤ **B-CONTROL MICRO Electronic Control Unit**

The B-CONTROL MICRO is a modern, easy-to-operate compressor control unit with colour display that intelligently controls and all basic compressor functions and monitors their safety. User-friendly navigation and clear display of all main compressor parameters.



B-CONTROL MICRO Display

Compressor control unit	B-CONTROL-MICRO
Ambient temperature:	-10°C to + 60°C (5-90% humidity; non-condensing)
Standard operating voltage	24 V DC
Protection class, control cabinet:	IP 55
Protection class, display:	IP 65
Type, display	3.5" colour display with clear text

**FEATURES**

- Displays current operating pressure, operating hours and operation type
- Displays remaining filling time for breathing air cylinders
- Semiautomatic and fully automatic operation options
- Standard SI unit selection for pressure and temperature
- User-friendly navigation and display (user interface)
- Displays service and maintenance intervals and maintenance information
- Password protection for various menu levels
- Log stores incident history
- Simple software update uses SD card
- Cycle counter and operating hours counter
  - Safety: Information when pressure vessels require replacement
- Numerous language options (German, English, French, Chinese (traditional and simplified), Czech, Danish, Dutch, Finnish, Italian, Japanese, Norwegian, Polish, Portuguese, Russian, Swedish, Spanish, Turkish and more)

**MONITOR / CONTROL FUNCTIONS**

- Oil pressure monitoring
  - Protection from incorrect rotation direction
- Condensate level monitoring
  - compressor shutdown when reaching the maximum level
- B-SECURUS monitoring (via CAN bus) as option
  - Safety: Shuts down compressor when filter cartridge is fully saturated
- Temperature monitoring
  - Safety: Monitors temperature (final stage)
- Motor overcurrent (indirect by PTC)
- Oil level monitoring (optional)

## INTERFACES

- CAN bus for internal use
- Remote Start/Stop (dry contact)
- External emergency off switch
- Centralised alarm (dry contact)
- External connection options for: B-SECURUS, SECCANT, B-KOOL , external display, external operating field, gas measurement systems, 60 litre condensate collector
- Ethernet connection for communication with the B-APP

### › Automatic condensate drain system B-DRAIN

The automatic condensate drain automatically removes the condensate that forms during compression (water/oil mixture) from the intermediate separators and the final separator and collects it in a condensate vessel, which is integrated in the compressor.

The newly developed and patented B-DRAIN automatic condensate drain uses individually controlled solenoid valves to ensure reliable, automatic condensate removal from the compressor separators.



B-DRAIN

Automatic condensate drain system	
Control voltage	24 V DC
Solenoid valve	normally open (NO)
Condensate collector capacity	approx. 14 l

## OPTIONS

### › SUPER SILENT housing

Super Silent compressor housing is fully noise-insulated with optimised cooling air intake. The Super Silent soundproofed housing is recommended for applications where reduced noise is a priority, e.g. work environments.

- Closed design features targeted cooling air intake.
- Housing parts are easy to remove, ensuring fast access for maintenance.
- An exhaust air duct is easy to fit.
- Reduces acoustic pressure to:
  - 67 -73 dB(A) ± 2 dB(A) (ISO 3744) according to compressor version
- Finish: Basic frame RAL 9006, housing RAL 9006 and RAL1028, CYAN
- The Super Silent housing can be retrofitted.



VERTICUS w

### › B-SECURUS filter cartridge monitoring system

The B-SECURUS System continuously monitors filter cartridge saturation levels by measuring the moisture in the molecular filter and showing a warning in the display of the B-CONTROL MICRO unit when it is time to change the cartridge. When the dryer cartridge is 100 % saturated the B-SECURUS automatically shuts down the system.

The B-CONTROL unit displays the following warnings:

- Green segment: Filter cartridge OK
- Yellow segment: Cartridge nearing saturation
- Red segment: Cartridge saturated or contact fault.  
Compressor is shut down

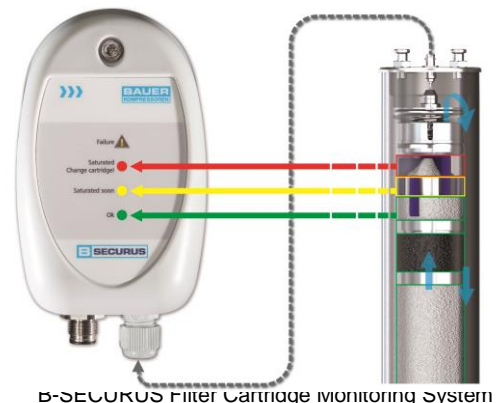

B-SECURUS Filter Cartridge Monitoring System

Filter cartridge monitoring unit	B-SECURUS
Supply voltage	24 V DC
Power consumption	3 VA
Contact switching capacity	6 A/250 V
Protection class	IP 65



➤ **Integrated B-DETECTION PLUS i gas measurement system**

The online gas measurement system B-DETECTION PLUS monitors the quality of the compressed air: Measurement of CO, CO<sub>2</sub>, O<sub>2</sub> as well as optional absolute humidity (as option) and VOC (as option). By means of the B-CONTROL control, you can at any time observe compliance with the limit values of the breathing air standard DIN EN 12021:2014. In the case of an exceedance of the limit, the control system will show an alarm on the display by means of an optical warning signal and switch off the system before air contaminated with pollutants enters the breathing air bottles.

An automatic flush valve (optional) ensures that the contaminated air is directed into the open air without interrupting the operation of the system if short-term limit values are exceeded.



VERTICUS with integrated B-DETECTION PLUS i

➤ **P61/420 Purification System - Filter with separate oil and water separator (for MINI-VERTICUS)**

**SCOPE OF DELIVERY:**

- 1x filter housing with long-life filter cartridge
- Separator unit with final pressure safety valve
- Check valve between separator and micro filter
- Micro filter
- Air bleeder valve with manometer
- Pressurizer / check valve
- Filter key for cartridge renewal

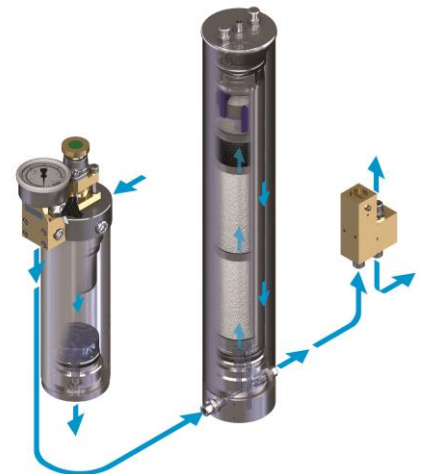

P61 purification system (picture similar)

**Air quality as per DIN/EN 12021:2014**

(see purification system in standard scope of delivery)

Purification system	P61/420
Operating pressure (Standard)	PN200/PN300/PN420
Operating pressure max (safety valve setting)	420 bar
Pressure dew point	< -20 °C, equivalent to 3 mg/m <sup>3</sup> at 300 bar
Piping connections	G 3/8" (condensate drain G 1/4")
Filter housing volume	2.85 l
DGRL 2014/68/EU	Vessel category II
Processable air capacity (with ref. 20°C and 300 bar) <sup>1</sup>	2,475 m <sup>3</sup>

<sup>1</sup> When using a BAUER P61 filter cartridge without hopcalite. When using a cartridge with CO<sub>2</sub>, the air purification capacity is reduced by approx. 10 %. Different values for SECURUS cartridges.

➤ **P81/420 Purification System - Filter with separate final oil and water separator (for VERTICUS)**

**SCOPE OF DELIVERY:**

- Separator with final pressure safety valve
- Check valve between separator and micro filters
- Two micro filters
- Air bleeder valve with manometer
- Pressuriser / check valve

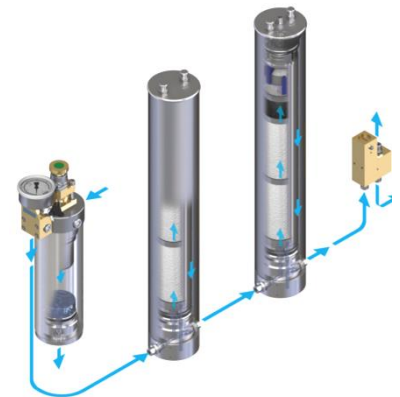

(picture similar)

**Air quality as per DIN/EN 12021:2014**

(see purification system in standard scope of delivery)

Purification system	P81/420
Operating pressure (standard)	PN200 / PN300
Operating pressure max (PS)	350 bar
Pressure dew point	< -20 °C, equivalent to 3 mg/m <sup>3</sup> at 300 bar
Piping connections	G 3/8" (condensate drain G 1/4")
Filter housing volume	2 x 2.85 l
DGRL 2014/68/EU	Vessel category II
Processable air capacity (with ref. 20°C and 300 bar) <sup>1</sup>	5.325 m <sup>3</sup>

<sup>1</sup> When using a BAUER P81 filter cartridge without hopcalite. When using a cartridge with CO-, the air purification capacity is reduced by ca. 1.5 %. Different values for SECURUS cartridges.

➤ **B-APP**

B-APP allows users to remotely control and monitor compressors with the new B-CONTROL MICRO. B-APP also offers additional features such as product-specific news, videos, an integrated dealer search function and calculation tools. Available in the AppStore (iOS) and on GooglePlay (Android).

As a requirement for the B-APP remote function, the B-CONTROL MICRO compressor control unit must have a valid IP address and be connected to the same local area network (LAN/WLAN) as the mobile device.

The integration of the B-CONTROL MICRO into the local network (home router, DSL router, company network) is implemented either via network cable or with optional LAN-WLAN gateway via wireless LAN.

Alternatively, if there is no local network for integration of the compressor control, an optional LAN-WLAN gateway can also be used to create a separate local WLAN network of the B-CONTROL MICRO. The smartphone can be logged into this network to permit use of the remote function in the B-APP.

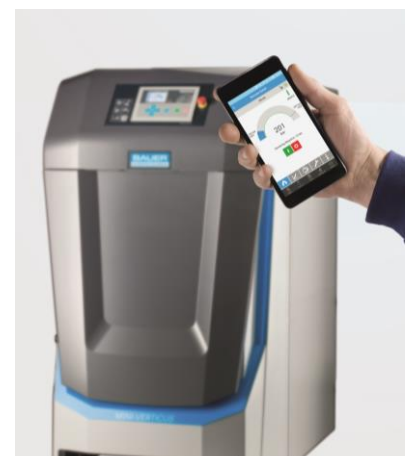

Controlling the MINI-VERTICUS with the B- APP

➤ **Particle filter**

In combination with the P41, P61 and P81 purification systems, an optional integrated particulate filter is available for effective protection against fine dust and other solid particles. This permits the reliable removal of particles in accordance with ISO 8573 class 2.

➤ **B-CONTROL II compressor control unit**

BAUER B-CONTROL II is the advanced version of the B-CONTROL MICRO basic compressor control unit. It features a touch screen display:

- Fully automatic operation in line with customer-specific parameters
- Monitors all relevant operating data
- Shuts down the system in the case of deviation from defined operating parameters
- Displays operating data, maintenance information, fault messages and trends
- Can be used as a master control unit

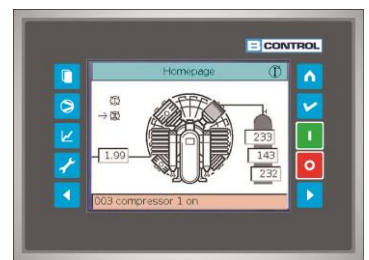

B-CONTROL II display

Compressor control unit	B-CONTROL II
Motor drive	Star delta starter
Output	7.5 kW
Control voltage	24 V DC
Type	Semi-automatic
Operating elements	5.7" TFT colour display 240 x 320 pixels; touch screen plus 10 function buttons, clear text display

Standard features

- 5.7" TFT colour touch screen display with clear text
- Fully automatic monitoring of relevant parameters; compressor shutdown if values exceed permissible ranges
- Choice of languages
- Oil pressure monitoring protects against incorrect rotation direction
- Maintenance information shown in display
- Log stores incident history
- Password protection for various menu levels
- Base load cycle and interconnected operation for up to 4 connected compressors
- Integrated data logger
- Cycle counter records load cycles of final separator stage
- Interface: USB 2.0, Ethernet 10/100, CAN bus Layer 2, Modbus RTU RS485, Profibus DP slave (optional)
- Remote On/Off (galvanically isolated)
- Centralised alarm (galvanically isolated)
- Simple software update via CF card or USB
- External connections for: [B-SECURUS](#), [SECCANT](#), [B-KOOL](#), external display, external operating panel, fill level, gas balloon, gas measurement systems

OPTIONS

- Monitoring of intermediate pressure throughout all compressor stages (using pressure sensor, values displayed in B-CONTROL II, compressor shutdown where permissible intermediate pressure is exceeded)
- Monitoring of temperature throughout all compressor stages (using Pt1000, values displayed in B-CONTROL II, compressor shutdown where permissible intermediate pressure is exceeded/underreached)
- Oil level monitoring for safe shutdown of the compressor system at low oil level.

➤ **Additional interstage separator after 1st stage**

In operation in regions with high humidity, e.g. tropical regions, we recommend installing an interstage separator after the first compression stage. This can lengthen the service life of the system and reduce maintenance costs.



Interstage separator

➤ **Interstage manometer set**

The interstage pressure manometers display the operating pressure for the individual compression stages. This pressure information enables the sealing tightness of the valves (intake and outlet) of each stage to be checked and potential fault sources to be rapidly identified. The interstage pressure manometers are mounted in the compressor housing.



Interstage manometer

➤ **Connection for external air intake**

When breathing air cylinders are filled the quality of the compressed air depends on the quality of the ambient intake air. Particularly where exhaust gases (CO) and exhaust air from other systems may occur in the room where the compressor is sited, the intake must take in pure fresh air from outside. In this case, a connection for an external air intake is planned.



➤ **Condensate collection system 60 l**

- 60-litre PVC tank, capacity approx. 40 litres
- Exhaust air is filtered by a soundproofed active charcoal filter
- Filling level display with visual warning when the collector requires emptying (optionally with signal for B-CONTROL)
- Drain tap for condensate, connector thread G 1/2"
- Dimensions: Ø 400 mm x 1.000 mm, weight approx. 15 kg



60 l condensate collection system

➤ **Exhaust air duct**

- Exhaust air duct for cooling air flow outlet at top with connection option for exhaust air channel
- For mounting on the compressor housing



Standard exhaust air duct

**Note: The exhaust air duct can only be mounted on the Super Silent housing!**

› **Exhaust air duct with ventilating shutters**

An exhaust air duct with ventilating shutters is used with compressors installed in a container or compressor room to regulate ambient temperature. At low ambient temperatures (e.g. < +5 °C) the heated cooling air heats the room; at high ambient temperatures the heated cooling air is directed outdoors.



Exhaust air duct with ventilating shutters mounted on a VERTICUS

**SCOPE OF DELIVERY**

- Exhaust air duct with canvas flange for exhaust channel (to be supplied on site)
- Louvres for circulating air control
- Actuating drive for louvres
- Electronic high - low action control system incl. temperature sensor (mounted in compressor air intake duct; set value +18 ± 4°C)
- Mounted on compressor housing incl. electric installation

Important: If the pressure drop is exceeded by 5 mmWS = 0.5 mbar (e.g. when the exhaust air duct is very long), an additional fan has to be provided on site.

The system can be mounted on the top or rear of the compressor (please state requirements when ordering).

› **Extended base frame**

The compressor and up to 2 storage bottles each with a geometric capacity of 50 or 80 litres are installed on the extended base frame, making this a turnkey system.



Extended base frame	
Weight <sup>1</sup>	33 kg
Dimensions (L x W x H) <sup>1</sup>	1920 x 790 x 1530 mm

<sup>1</sup> Without storage bottles.

› **High-pressure storage systems**

Modular high-pressure storage system for storage of air / gases, extendable. The storage units can be set up separately or on an extended basic frame (to be ordered separately).

The extended basic frame enables the compressor and up to 2 storage cylinders with a geometric volume of 50 / 80 litres each to be combined in a turnkey system.



B50

B100

**SCOPE OF DELIVERY:**



# (MINI-)VERTICUS 420 bar

▪ **B 80 S / B 160 S – Standard module**

Storage cylinder(s) upright, mounted on console, connection at bottom, with safety valve and manometer, globe valve and condensate drain / air bleeder valve.

▪ **B 80 A / B 160 A – Extension module**

To extend the above standard modules as required for storage of high volumes.  
 Scope of delivery as standard module but without safety valve and manometer;  
 where multiple storage cylinders are to be added, a connection is required for each additional extension module.

▪ **B 80 B, without console**

Storage cylinder, with cylinder valve; excluding condensate drain valve  
 Option: Clamp for wall mounting, safety valve (supplied loose)  
 Where multiple storage cylinders are to be added, a connection is required for each additional extension module.

▪ **B 50 S / B 100 S - Standard module**

Storage cylinder(s) upright, mounted on console, connection at top (360 bar) or at bottom (420 bar), with safety valve and manometer, globe valve and condensate drain / air bleeder valve.

▪ **B 50 A / B 100 A - Extension module**

To extend the above standard modules as required for storage of high volumes.  
 Scope of delivery as standard module but without safety valve and manometer;  
 where multiple storage cylinders are to be added, a connection is required for each additional extension module.

**FINISH:**

Console RAL 7024 (grey) Storage container RAL9010 (white for B80/160) or RAL 7024 (grey for B50/100).

	Up to 330 bar		Up to 420 bar	
	B 80	B 160	B 50	B 100
Numbers of storage bottles:	1	2	1	2
Storage medium:	Air, Nitrogen, Rare gases			
Geometric volume cylinder:	80 Litre		50 Litre	
Geometric volume storage:	80 Litre	160 Litre	50 Litre	100 Litre
Safety valve max.:	330 bar		420 bar	
Storage pressure max.:	320 bar		400 bar	
Weight:	145 kg		125 kg	250 kg
Design as per:	DGLR 2014/68/EU and AD2000 <sup>1</sup>			

<sup>1</sup> Other certificates / approvals on request.

➤ **Automatic selector unit**

The automatic selector unit enables pressurised air cylinders (bottles) to be filled rapidly and in parallel from a buffer (intermediate storage system and by the compressor.



**SCOPE OF DELIVERY**

- Painted steel baseplate for wall mounting
- Pressuriser valve
- Check valve
- Pressure switch or pressure sensor, depending on the connected compressor control unit
- Manometer for filling pressure
- Manometer for storage pressure

<b>Automatic selector unit</b>	
Medium	Pressurised air
Ambient temperature	+5 °C to +45°C
Operating pressure	Max. 350 or 420 bar (depending on design)
Air intake/outlet	10 mm (outside connector diameter)

➤ **B-KOOL refrigeration dryer**

The B-KOOL Refrigeration Dryer cools the compressed air and thus extends the service life of filter cartridges many times over.

The B-KOOL cools the hot saturated air in the compressor to approx. +3 °C, enabling the final separator to extract significantly higher volumes of condensate and thus extending the service life of the downstream filter cartridges. Depending on the ambient temperature, the life of the filter cartridges can be significantly extended. The higher the ambient temperature, the longer the lifespan of the filter cartridges when the B-KOOL is used.



B-KOOL mounted on a VERTICUS housing

**TYPES**

- B-KOOL II 680i, integrated (mounted on a (MINI-) VERTICUS with Super Silent housing)
- B-KOOL 680s standalone positioned next to the compressor



Model	B-KOOL 680i and B-KOOL 680s
Medium	Compressed air
Ambient temperature	+5 °C to +45°C
Refrigerant	R 134 a
Intake temperature of pressurised air	max. 60°C
Max. operating pressure, pressurised air	350 bar / 500 bar
Min. operating pressure, pressurised air	100 bar
Permissible compressor charging rate	200 – 700 l/min (10 l cylinder filling from 0-200 bar ) 200 – 650 l/min (as per ISO 1217)
Power supply	100 – 127 VAC 50 Hz or 200 – 240 VAC 50/60 Hz
Power consumption	max. 550 W at 50 Hz, 610 W at 60 Hz

## DIMENSIONS; WEIGHT AND CONNECTIONS

Model	B-KOOL 680i	B-KOOL 680s
Dimensions (L x W x H)	550 x 792 x 390 mm	386 x 695 x 565 mm
Weight approx.	57 kg	48 kg

## ASSEMBLY KITS

Suitable for purification systems P41 and P61. **The assembly kit for mounting on a compressor must be ordered separately and is essential.**

➤ **AERO-GUARD CO<sub>2</sub> absorber**

**Efficient removal of CO<sub>2</sub> from breathing air:** A sophisticated bypass system feeds the compressor intake air through the AERO-GUARD. Only around two-thirds of the air passes through the filter cartridge that absorbs the CO<sub>2</sub> from the air. This process reduces the CO<sub>2</sub> content to one-third of that of the intake air.



AERO-GUARD

**SCOPE OF DELIVERY, AERO-GUARD:**

- Intake pipe (order connections separately)
- Water barrel, 60 l (for AERO-GUARD DUO – 2 x water barrels each 60 l)
- Filter cartridge; filling: 9 kg special carbon dioxide absorber

**MODELS:**

Type / Size	Suitable for charging rate <sup>1</sup>	Dimensions (W x D x H)	Operating weight <sup>2</sup>
	l/min	cm	
<b>Aero-Guard-S</b>	100 – 150	50 x 46 x 72	26 kg
<b>Aero-Guard-M</b>	160 – 230		
<b>Aero-Guard-L</b>	240 – 320		
<b>Aero-Guard-XL</b>	330 – 450		
<b>Aero-Guard-XXL</b>	460 – 700		
<b>Aero-Guard Duo 1000</b>	650 – 1000	85 x 62.5 x 87	54 kg

<sup>1</sup> Charging rate of the connected compressor measured with cylinder filling from 0 – 200 bar ± 5%.

<sup>2</sup> Includes filter cartridge and 10-litre water ballast.

**TECHNICAL OPERATING DATA:**

Model	AERO-GUARD S-XXL	AERO-GUARD DUO 1000
Medium	Pressurised air	
Ambient temperature	+5 to +45°C	
Intake air temperature	+5 to +45 °C	
Rel. humidity of intake air	10 to 100 %	
CO <sub>2</sub> intake air concentration	max. 1000 ppm <sub>v</sub> CO <sub>2</sub>	
CO <sub>2</sub> output air concentration	1/3 of intake concentration = max. 330 ppm <sub>v</sub> CO <sub>2</sub> at 1,000 ppm <sub>v</sub> intake concentration CO <sub>2</sub>	
Designed for compressor charging rate	100 – 700 l/min	650 – 1,000 l/min
Service life	Min. 43 operating hours (at 700 l/min output and intake concentration of 1000 ppm CO <sub>2</sub> ). Cartridge must be changed after max. one year even if the maximum service life is not reached.	Min. 60 operating hours (at 1000 l/min output and intake concentration of 1000 ppm CO <sub>2</sub> ). Cartridge must be changed after max. one year even if the maximum service life is not reached.
Maximum daily operating time:	5 h	
Cartridge filling:	Approx. 9 kg special carbon dioxide absorber per cartridge	
Pressure loss	Approx.20 mbar	
Max. permissible tilt	15°	
Permissible altitude	0 - 2000 m AMSL	
Finish	Container blue, cover black/silver, PVC pipes grey RAL7011	

---

**Relevant EC Directives (where applicable)**

- › EC Machinery Directive (2006/42/EC)
- › EC Pressure Equipment Directive (2014/68/EU)
- › EC Low Voltage Directive 2006/95/EC
- › EC Electromagnetic Compatibility (EMC) 2004/108/EC

**Applied national standards and technical specifications, in particular**

- › Betriebssicherheitsverordnung (German Industrial Safety Regulation) of 27 September 2002
- › AD 2000
- › Unfallverhütungsvorschrift (BGR; German Accident Prevention Regulations) BGR 500
- › All BAUER filter housings are designed, manufactured and tested in line with Accident Prevention Regulations and regulations under AD-2000 provisions and DGRL 2014/68/EU.

**Documentation:** 1x operating manual and parts list with exploded view drawing on DVD

**Design:** In line with the state of the art according to DIN, VDE, TÜV and Accident Prevention regulations

**Testing:** In line with Bauer Standard as per DIN EN 10204 - 3.1

Otherwise the **General Terms and Conditions of BAUER KOMPRESSOREN (AGB)** in the version valid at the time of contract conclusion apply. These Terms & Conditions can be viewed and downloaded at the website "[www.bauer-kompressoren.com](http://www.bauer-kompressoren.com)", or sent by BAUER on request.

All information is given without assumption of liability and subject to technical changes.